

FOTO 1

FOTO 2

#	DESCRIPTION	PART NUMBER	QTY
1	Collettore #1 / Down pipe #1	9773K044S2A	1
2	Collettore #2 / Down pipe #2	9773K044S2B	1
3	Tubo di raccordo 2-1 / Link pipe 2-1	9773K057S2C	1
4	Tubo di raccordo / Link pipe	9773K058S2D	1
5	Dado M8 flangiato / Flanged nut M8	50.73.393.1	6
6	Vite M8x45 / Screw M8x45	50.73.602.1	1
7	Rondella in alluminio nera / Black aluminium washer	50.73.221.1	1
8	Boccola / Bush	50.73.381.1	2
9	Silentblock / Silentblock	50.73.380.1	1
10	dB Killer forato / Drilled dB killer	50.DK.126.0	1
11	Silenziatore / Muffler db killer 50.DK.117.0	GP PRO 250	1
12	Vite M8 x 16 / Screw M8 x 16	50.73.098.1	3
13	Rondella di sicurezza / Safety washer	50.73.604.1	3
14	Staffa / Bracket	50.SS.1216.0	1
15	Staffa / Bracket	50.SS.990.0	1
16	Molla media / Mid-size spring	50.73.359.1	5
17	Tubo in gomma per molla / Rubber pipe for spring	50.73.210.1	3

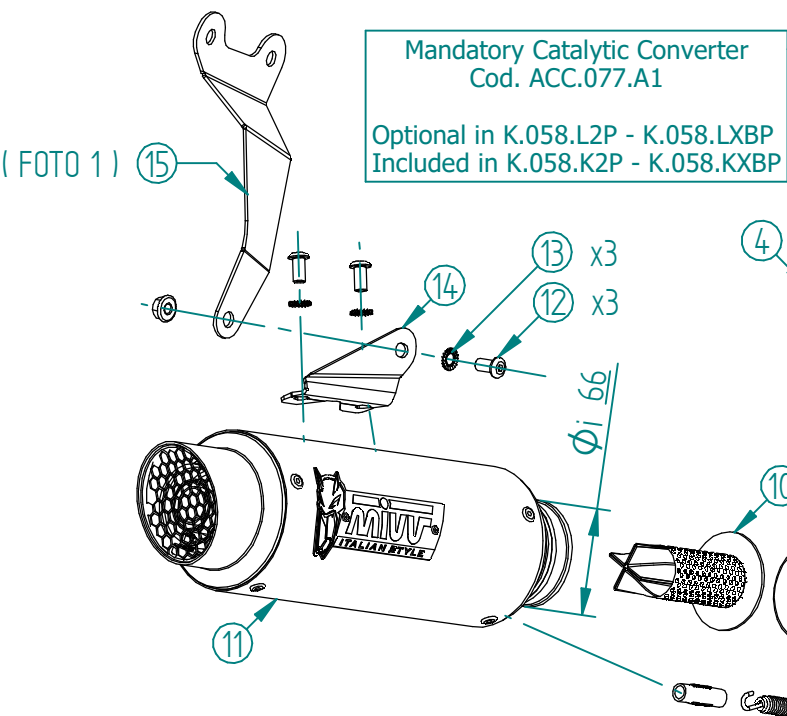
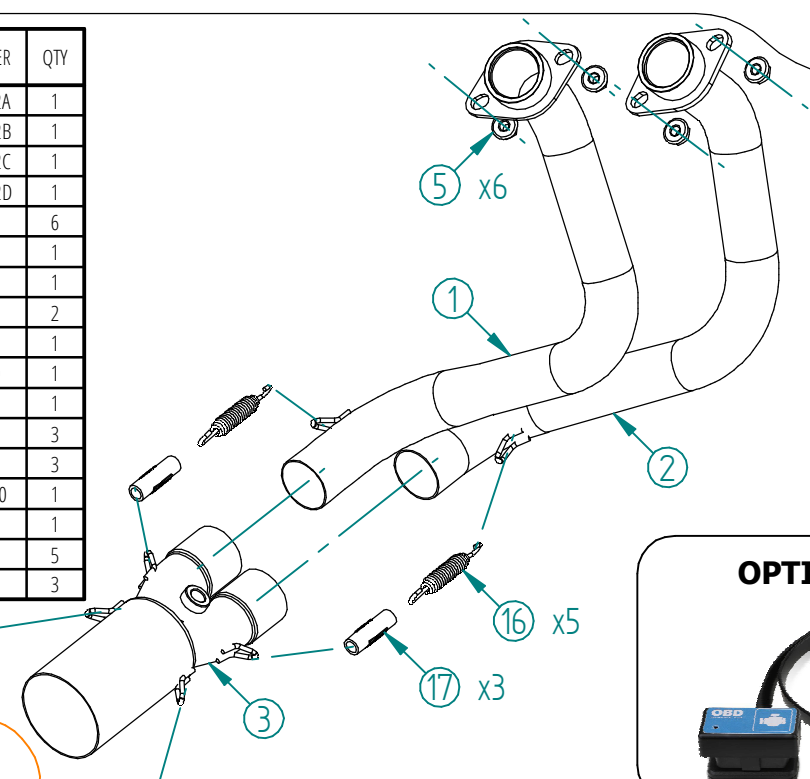

OPTIONAL PART

SWITCH-OFF KEY
Cod. ACC.101.0

Telaio / Frame (FOTO 2)



APPLICAZIONI / APPLICATIONS				
CODICE / CODE	SILENZIATORE / MUFFLER	LOGO	NOTE	TUBO / PIPE
K.058.L2P	CARBONIO / CARBON FIBER	ALUMINIUM LABEL	CATALYTIC CONVERTER	INOX / ST. STEEL
K.058.LXBP	STEEL BLACK	LASER	NOT INCLUDED	
K.058.K2P	CARBONIO / CARBON FIBER	ALUMINIUM LABEL	CATALYTIC CONVERTER	
K.058.KXBP	STEEL BLACK	LASER	INCLUDED	

ATTENZIONE: La rimozione del riduttore di rumore è considerata una manomissione dell'impianto di scarico che comporta la perdita dell'omologazione per utilizzo stradale e della garanzia prodotto. In caso di rimozione del riduttore di rumore l'impianto di scarico è in configurazione "racing" e può essere utilizzato solo in pista. La griglia frangifiamma può essere rimontata anche in assenza del riduttore di rumore, tuttavia l'impianto resta in configurazione "racing" e utilizzabile esclusivamente in pista.

WARNING: Removal of the noise reducer is considered a tampering of the exhaust system which entails the loss of both the type approval for road use and the product warranty. In case of removal of the noise reducer the exhaust system is in "racing" configuration and can be only used on track. The flame arrester can be reassembled even without the noise reducer, however, the system remains in "racing" configuration and can be only used on track.