

#	DESCRIPTION	PART NUMBER	QTY
1	Collettore #1 / Down pipe #1	9773Y080S3A	1
2	Collettore #2 / Down pipe #2	9773Y080S3B	1
3	Tubo di raccordo 2-1 / Link pipe 2-1	9773Y080S3C	1
4	Tubi di raccordo / Link pipe	9773Y080S3D	1
5	Silenziatore / Muffler db killer 50.DK.211.0	SR-1 350	1
6	Vite M8x30 / Screw M8x30	50.73.219.1	1
7	Rondella in alluminio nera / Black aluminium washer	50.73.221.1	1
8	Rondella di sicurezza / Safety washer	50.73.604.1	2
9	Vite M8 x 16 / Screw M8 x 16	50.73.098.1	2
10	Staffa / Bracket	50.55.1260.0	1
11	Dado M8 flangiato / Flanged nut M8	50.73.393.1	1
12	Tubo in gomma per molla / Rubber pipe for spring	50.73.210.1	3
13	Molla media / Mid-size spring	50.73.359.1	3
14	Molla lunga / Long spring	50.71.080.1	2

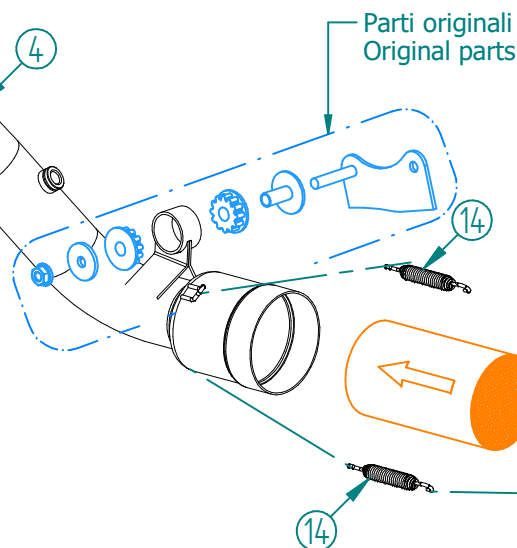

Mandatory Catalytic Converter
Cod. ACC.099.A1

Optional in Y.080.LR1XB / LR1TB
Included in Y.080.KR1XB / KR1TB

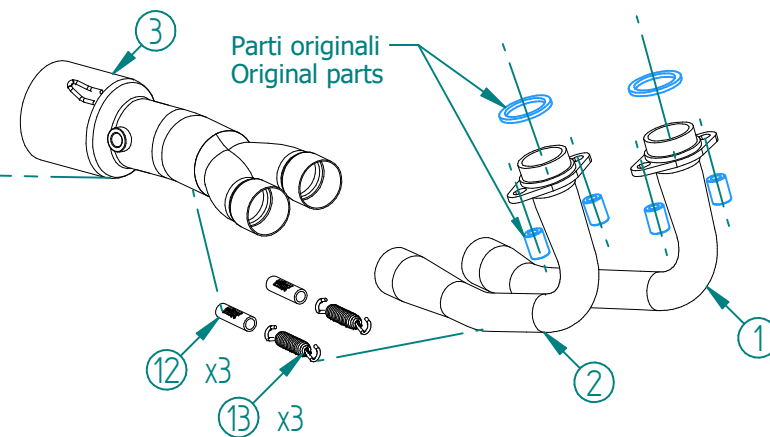

OPTIONAL PART



APPLICAZIONI / APPLICATIONS		
CODICE / CODE	SILENZIATORE / MUFFLER	NOTE
Y.080.LR1TB	TITANIO NERO (COPPA CARBONIO) / BLACK TITANIUM (CARBON CAP)	CATALYTIC CONVERTER NOT INCLUDED
Y.080.LR1XB	INOX NERO (COPPA CARBONIO) / STEEL BLACK (CARBON CAP)	CATALYTIC CONVERTER NOT INCLUDED
Y.080.KR1TB	TITANIO NERO (COPPA CARBONIO) / BLACK TITANIUM (CARBON CAP)	CATALYTIC CONVERTER INCLUDED
Y.080.KR1XB	INOX NERO (COPPA CARBONIO) / STEEL BLACK (CARBON CAP)	CATALYTIC CONVERTER INCLUDED